

**WIKK** Balanced Door Parts . EXCEL MANUAL  
BALANCED DOOR HARDWARE

INSTALLATION INSTRUCTIONS ----- CONCEALED HINGE TUBES

(POST 1999)

5-7-01

**GENERAL**

Read instructions thoroughly before installation.

Balanced doors are more complex than regular swing doors, therefore more time is required for installation. Balanced doors should open and close easily. They must be installed to operate without binding, rubbing or friction.

**DO NOT USE ANY LUBRICANTS**

Bearings and pivot points are to be oil and grease free. Oil and grease will collect dirt and grit which will hamper balanced door operation. It will also void the warranty.

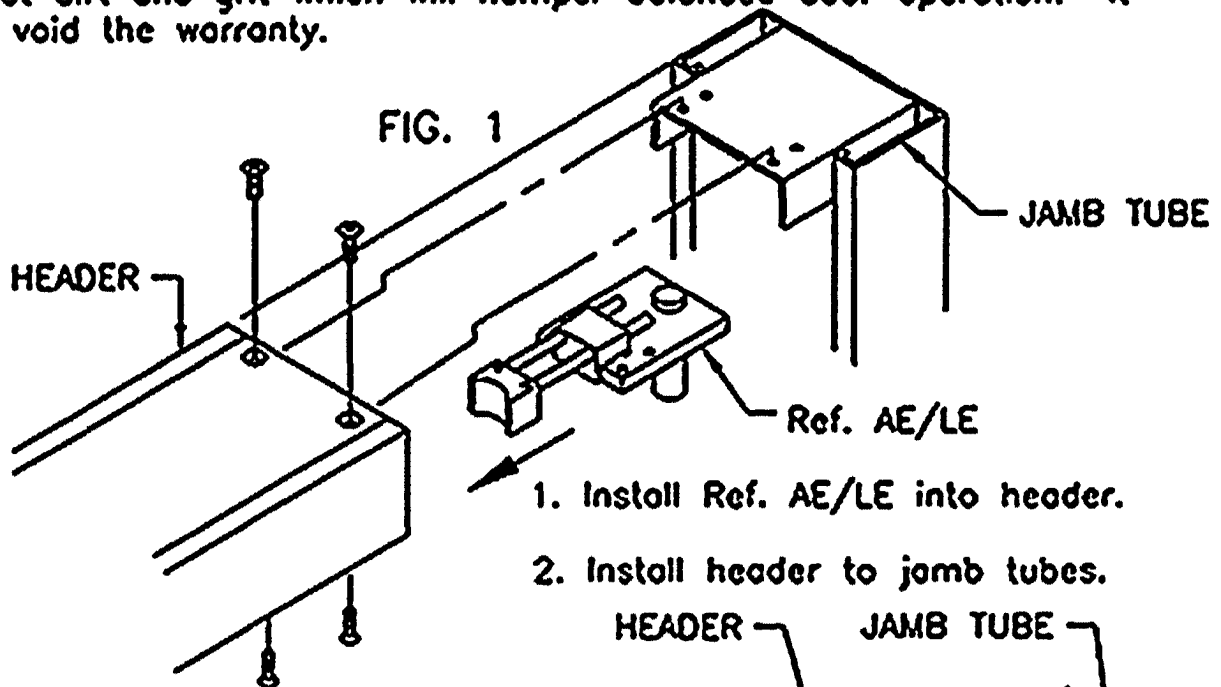

1. Install Ref. AE/LE into header.
2. Install header to jamb tubes.

3. Install door frame solid, true and plumb.

The center distance between the hinge tube pivot (Ref. 146) and the top hinge tube pivot (Ref. AE/LE) should be 1/32". See FIG. 2.

**IMPORTANT** - The hinge tube pivot plate must be on masonry floor or permanent metal shims to maintain proper door alignment. Use adequate anchors.

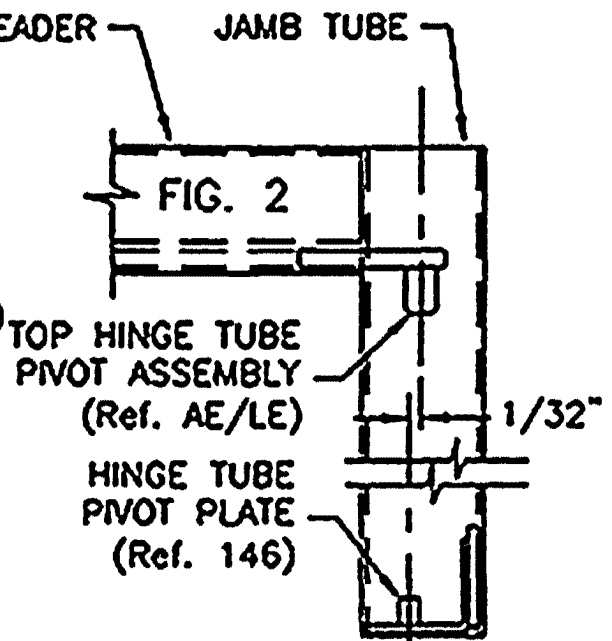

4. Place one thick shim washer (Ref. 36) over pivot and beneath adjusting gear bracket (Ref. 131). See FIG. 4.

5. Remove Ref. AE/LE. Set the hinge tube assembly on the pivot pin. Reinstall Ref. AE/LE. Check for 1/8" clearance between top of arm and header. **CAUTION** - Arms have toe-in. Check clearance close to hinge tube. Be sure gear teeth are engaged with adjusting gear bracket (Ref. 131). Add or remove shim washers (Ref. 36) as required to achieve the desired clearance.

6. Install jamb cover. The cover cannot be installed after the door is hung.

7. Install threshold.

8. Gently set the door on the bottom balance arm, engaging the bottom door pivot.

9. Guide bottom arm around to the interior side of the entrance, engage the guide roller in track in the header, slightly close the door to align the top door pivot with the top arm. Be careful not to nick up the guide roller while guiding it into the track. Spring top arm up slightly if necessary, and insert top pivot pin (Ref. 17). Tighten set screw (Ref. 47). See FIG. 5

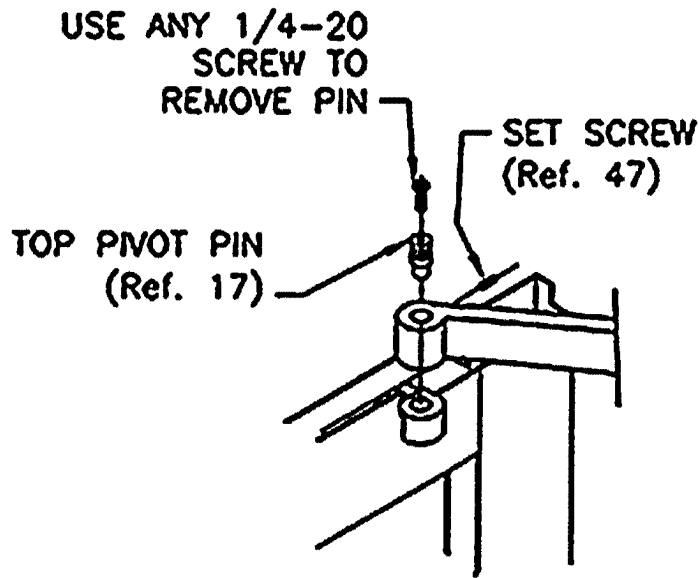

FIG. 5

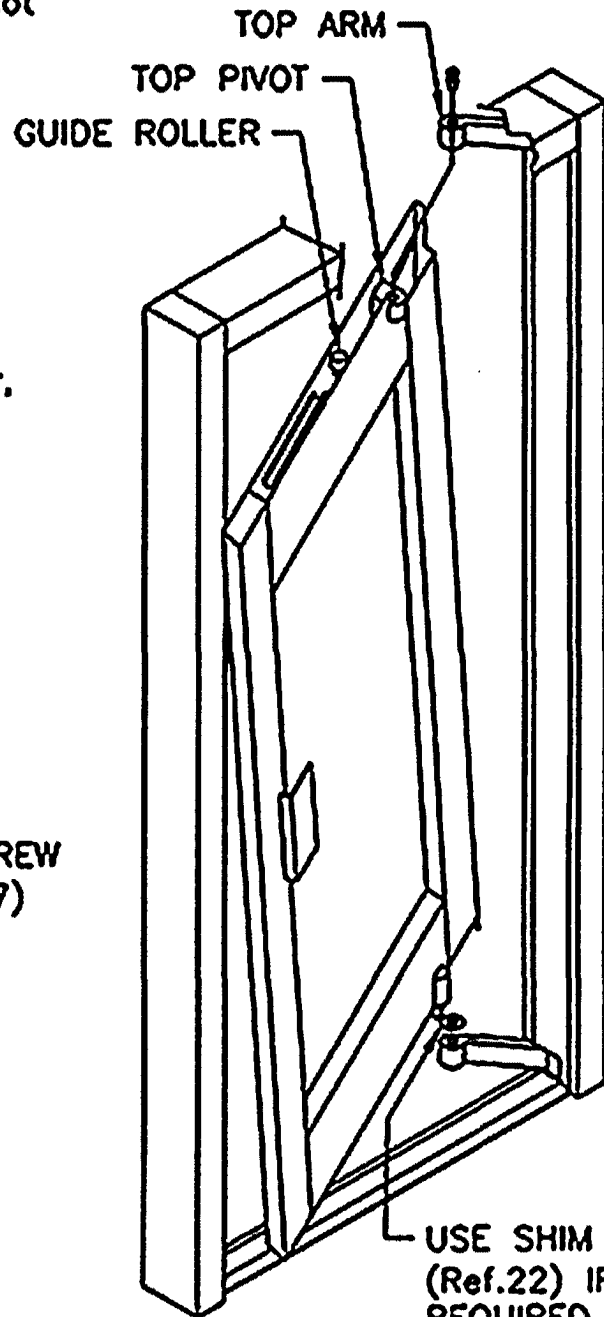
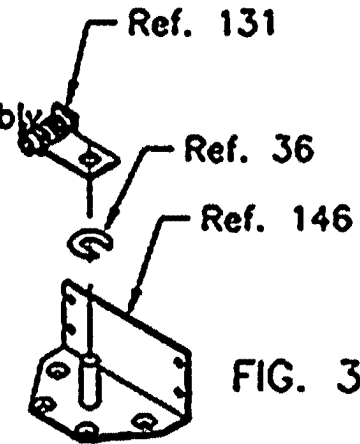
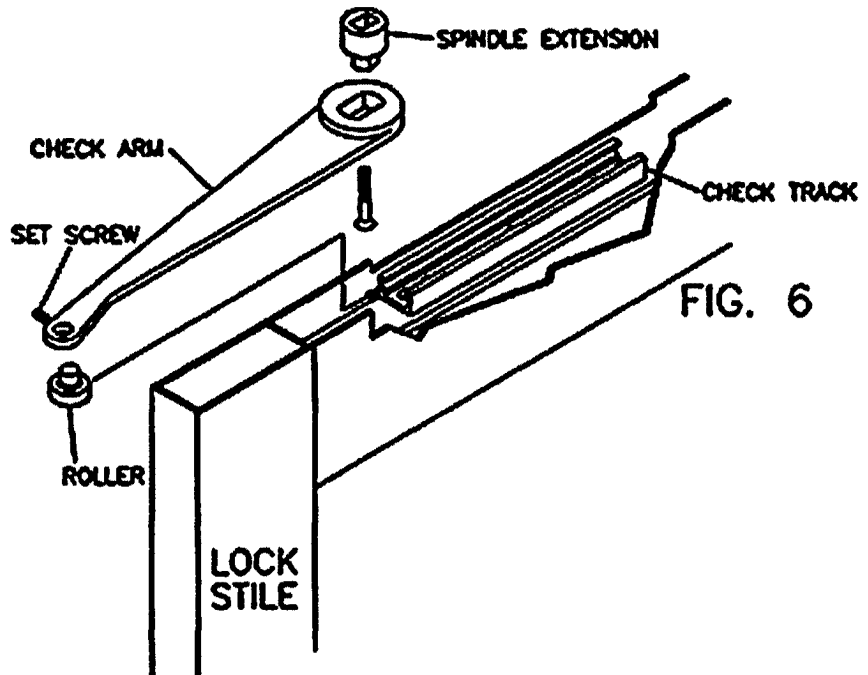
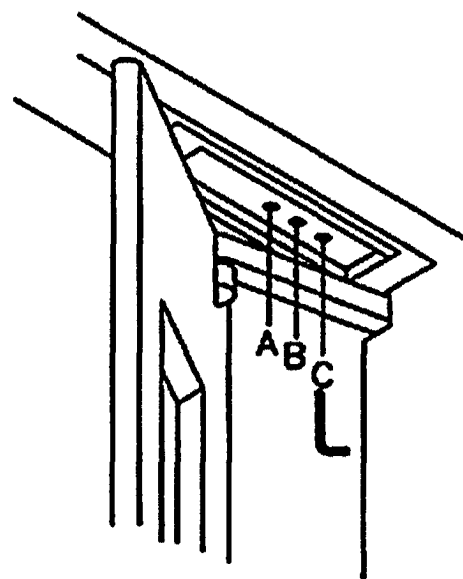
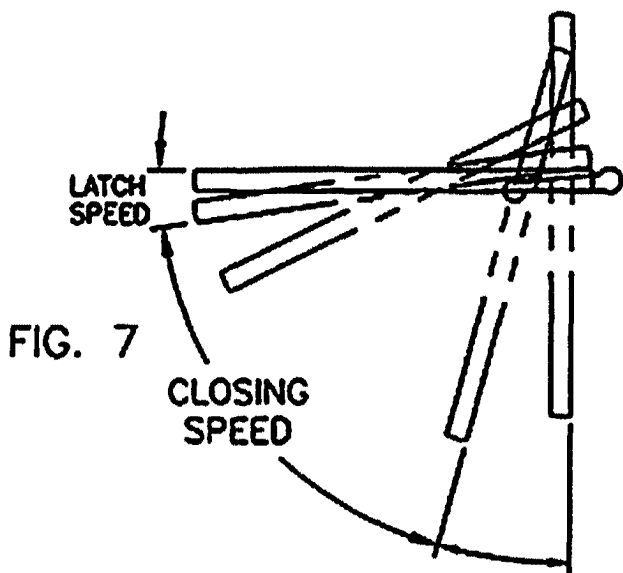

FIG. 4

10. Immediately check to see that the door does not rub on the bottom arm. There should be a 1/16" gap between the door and the bottom arm. Use shim (Ref.22) if required. See instruction sheet titled "Door Clearances" for further information concerning clearances required. NOTE: Pivots located in the door can be adjusted side to side to achieve clearances required.



11. Install the roller arm into the check track mounted in the door. Now attach the roller to the check arm and tighten the set screw. Attach the check arm to the closer and spindle extension. Without any tension on the door, check that the door rolls smoothly. Correct any binding there might be before adjusting the main closing force (Step 13).



12. Adjust the main closing force (see FIG. 9).

A. Retract but do not remove the locking screw. Use a #3 phillips head driver to turn the adjusting screw.

B. Adjust spring force to 8 lbs. opening force with the adjusting screw. Measure with a push or pull gage on the lock stile. Turning the adjusting screw clockwise increases tension and counterclockwise decreases tension.

C. Seat locking screw. If not, tension will slowly unwind.

13. Door check adjustments (see FIG. 7 & FIG. 8)

A. Back Check (to be adjusted first). Door check (Ref. 142) is not a closer. It has no spring tension. Set differently than regular doors. Use a very light back check setting so that it is not felt during average slow opening, yet will arrest door speed without racking the door if thrown open.

B. Closing Speed (to be adjusted second)  
To change closing speed of the door, turn the adjusting screw clockwise to slow down and counterclockwise to speed up.

C. Latch Speed (to be adjusted third)  
The latch speed should be set so the door doesn't bounce off the jamb or head stop but does fully close. Turn the adjusting screw clockwise to slow down and counterclockwise to speed up.

NOTE: TURNING THE ADJUSTING SCREWS TOO FAR OPEN WILL CAUSE OIL LEAKING.

14. Apply the door stop.

A. Set the door stop at  $3/32$ " from the face of the door.

B. Drill  $3/32$ " dia. holes in the jamb cover and the door stop for the mounting screws.

C. Install mounting screws.

15. Make sure top hinge tube pivot screw and top door pivot shaft set screws are tight. Check all points for interference or lack of clearance.

**USE NO LUBRICANTS.**

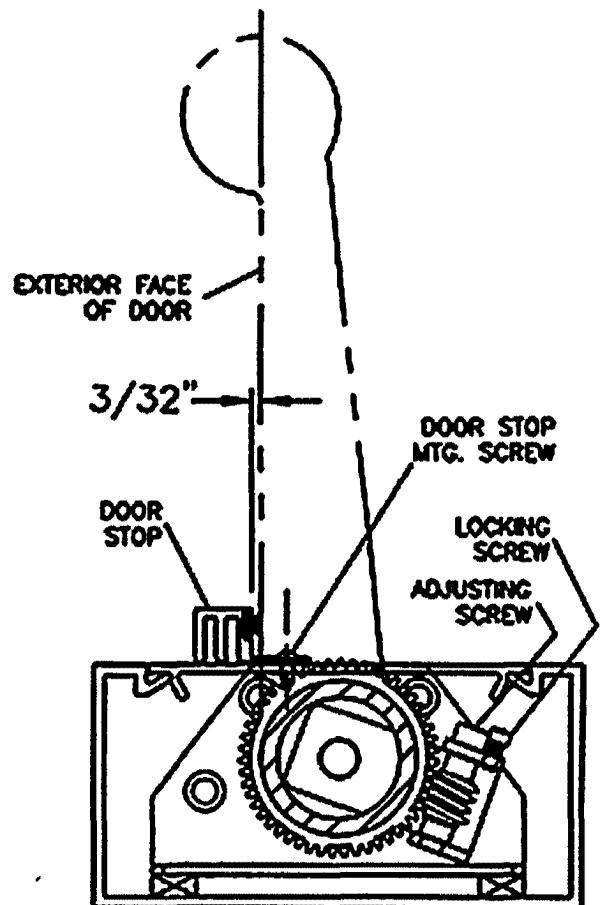

FIG. 9

**WIKK** Balanced Door Parts

PACIFIC DOOR & CLOSER CO., INC.  
725 Cesar Chavez, San Francisco, CA 94124  
Phone: (800) 995-0573  
Fax: (800) 962-2893  
[www.pacificdoorcloser.com](http://www.pacificdoorcloser.com)