

INSTALLATION INSTRUCTIONS ----- EXPOSED HINGE TUBES

(POST 1999)

5-7-01

GENERAL

Read instructions thoroughly before installation.

Balanced doors are more complex than regular swing doors, therefore more time is required for installation. Balanced doors should open and close easily. They must be installed to operate without binding, rubbing or friction.

DO NOT USE ANY LUBRICANTS

Bearings and pivot points are to be oil and grease free. Oil and grease will collect dirt and grit which will hamper balanced door operation. It will also void the warranty.

1. Install Ref. AE/LE to the fixed cover in the header. See FIG. 3 for proper alignment.

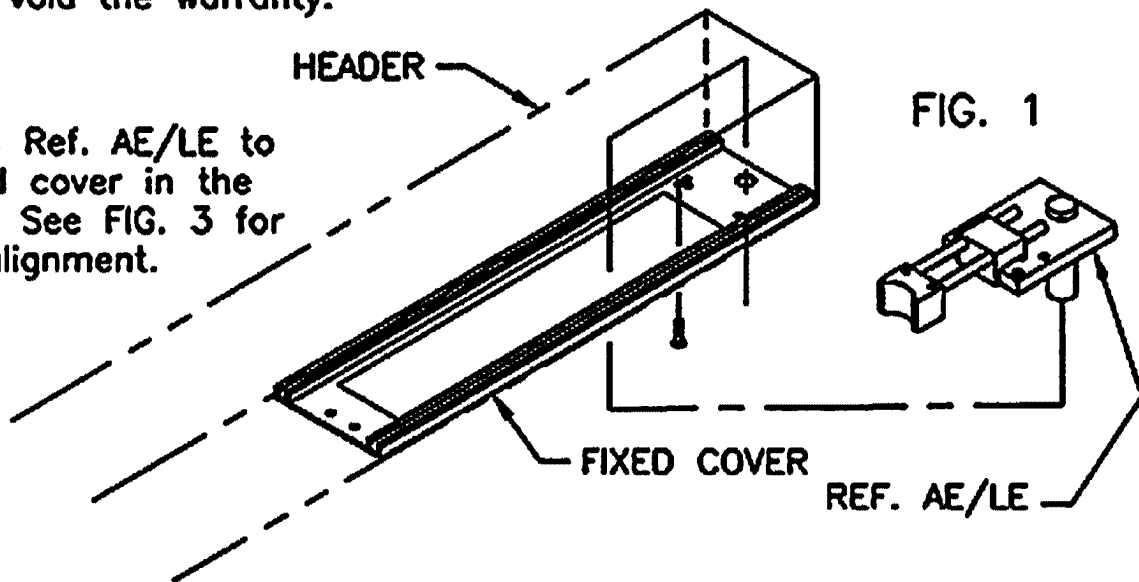

2. Install hinge tube pivot plate (Ref. 128). Install finish plate (Ref. 147) or threshold if desired. See FIG. 3 for proper alignment.

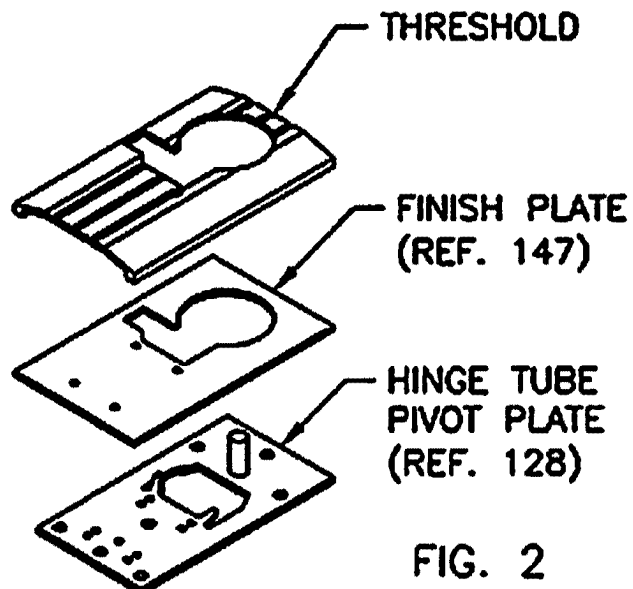

IMPORTANT - The hinge tube pivot plate must be on masonry floor or permanent metal shims to maintain proper door alignment. Use adequate anchors.

FIG. 2

3. Install header solid, true and plumb.

The center distance between the hinge tube pivot (Ref. 128) and the top hinge tube pivot (Ref. AE/LE) should be $1/32$ ". See FIG. 3.

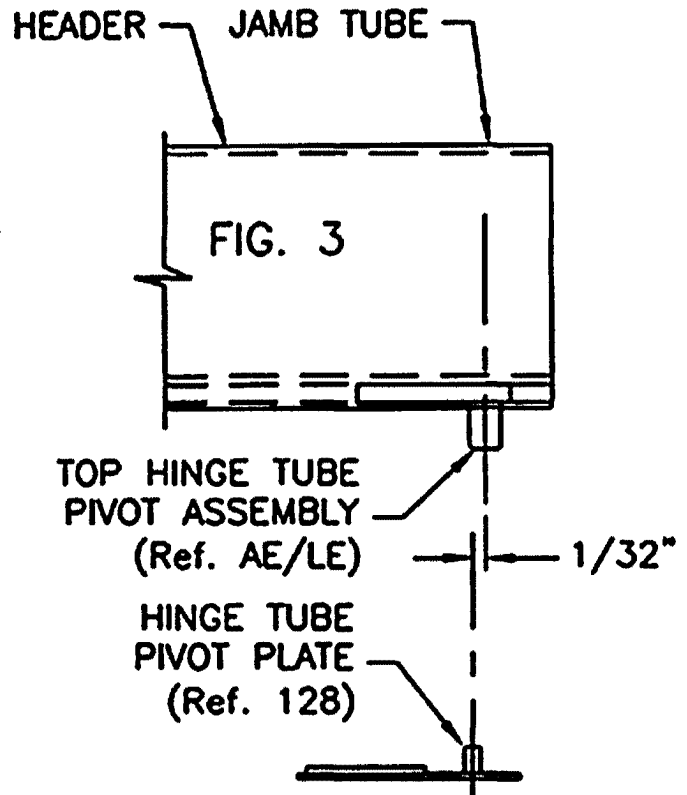

4. Place one thick shim washer (Ref. 36) over pivot and beneath adjusting gear bracket (Ref. 129). See FIG. 4.

5. Remove Ref. AE/LE. Set the hinge tube assembly on the pivot pin. Reinstall Ref. AE/LE. Check for $1/8$ " clearance between top of arm and header. **CAUTION** - Arms have toe-in. Check clearance close to hinge tube. Be sure gear teeth are engaged with adjusting gear bracket (Ref. 129). Add or remove shim washers (Ref. 36) as required to achieve the desired clearance.

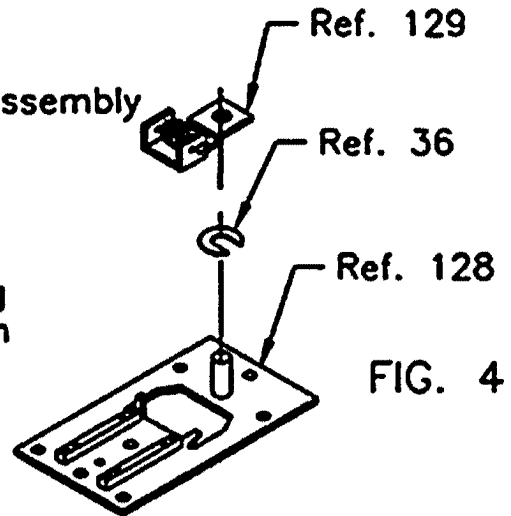

FIG. 4

6. Gently set the door on the bottom balance arm, engaging the bottom door pivot.

7. Guide bottom arm around to the interior side of the entrance, engage the guide roller in track in the header, slightly close the door to align the top door pivot with the top arm. Be careful not to nick up the guide roller while guiding it into the track. Spring top arm up slightly if necessary, and insert top pivot pin (Ref. 17). Tighten set screw (Ref. 47). See FIG. 6

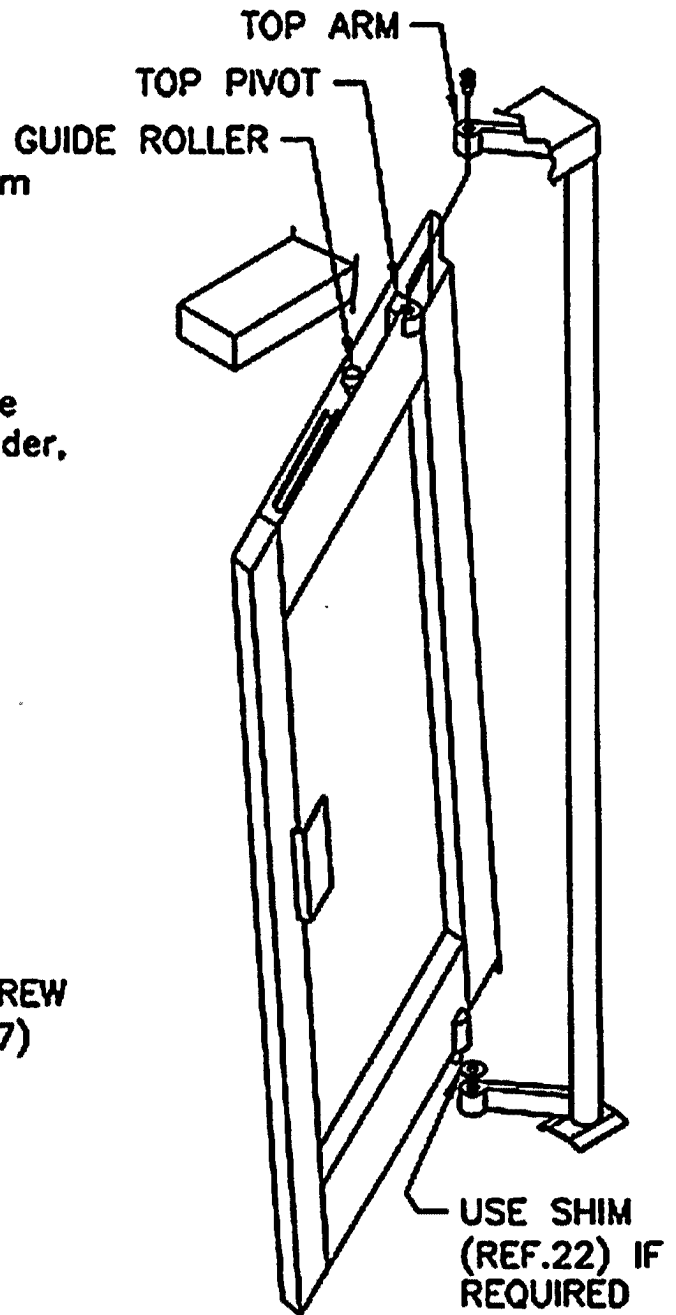

FIG. 5

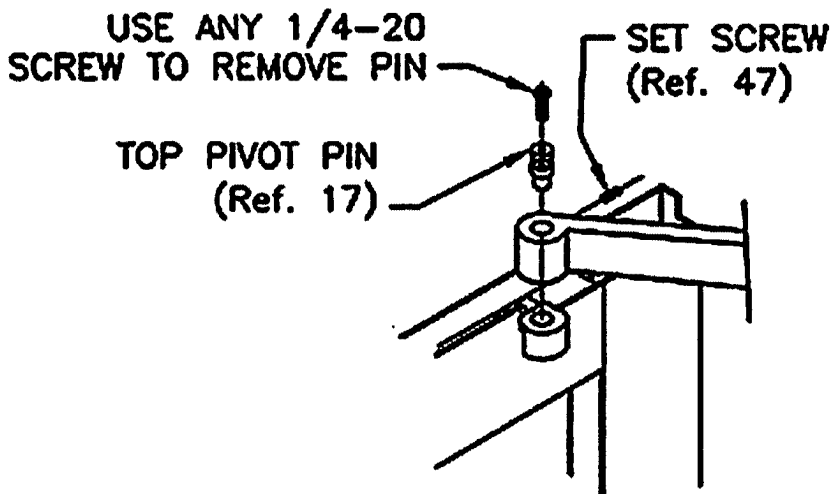
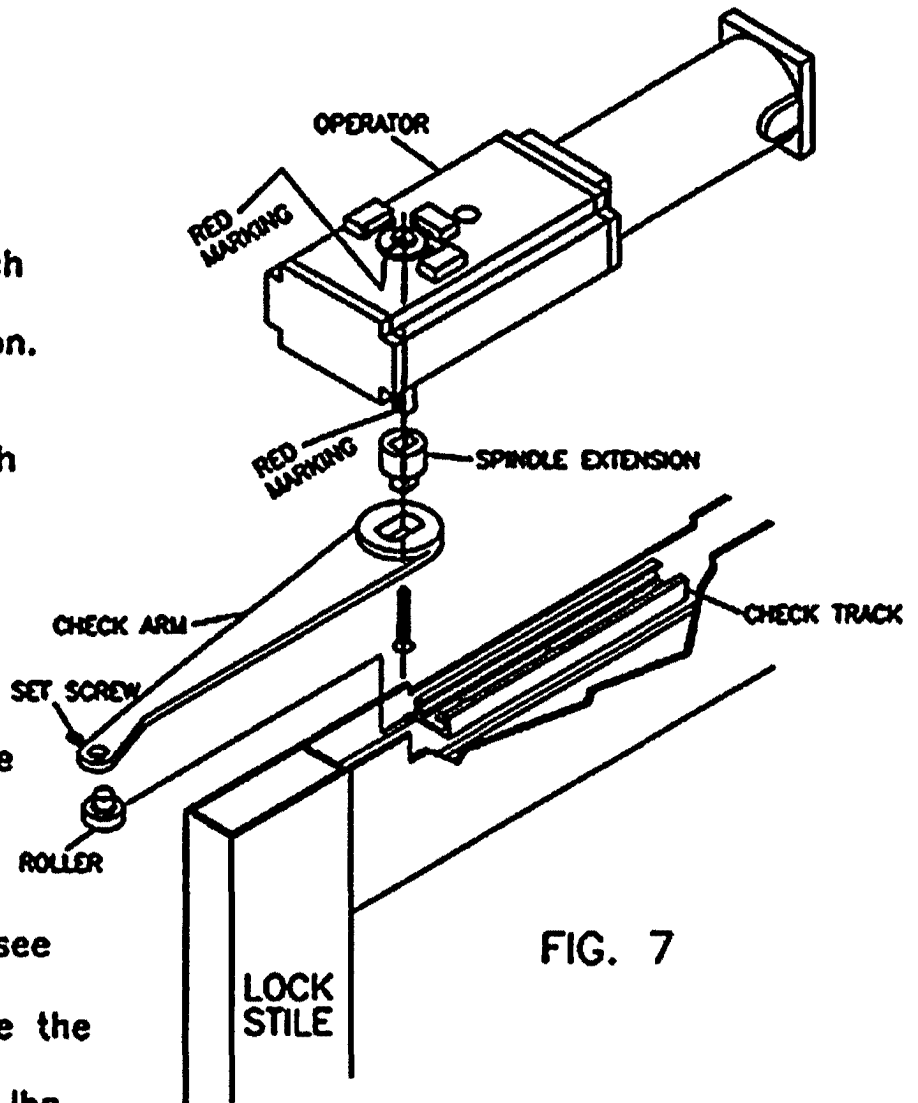

FIG. 6

8. Immediately check to see that the door does not rub on the bottom arm. There should be a 1/16" gap between the door and the bottom arm. Use shim (Ref.22) if required. See instruction sheet titled "Door Clearances" for further information concerning clearances required. NOTE: Pivots located in the door can be adjusted side to side to achieve clearances required.

9. Install the roller arm into the check track mounted in the door. Now attach the roller to the check arm and tighten the set screw. Attach the check arm to the operator and spindle extension. With the door in the closed position the red markings of the operator shaft and switch cam should be aligned as shown.



Without any tension on the door, check that the door rolls smoothly. Correct any binding there might be before adjusting main closing force (Step 10).

10. Set main closing force (see FIG. 8).

A. Retract but do not remove the locking screw.

B. Adjust spring force to 15 lbs. opening force with the locking screw. Measure with a push or pull gage on the lock stile. Turning the adjusting screw clockwise increases the tension and counterclockwise decreases tension. Be sure to use a #3 phillips driver to turn the adjusting screw.

C. Seat locking screw. If not, tension will slowly unwind.

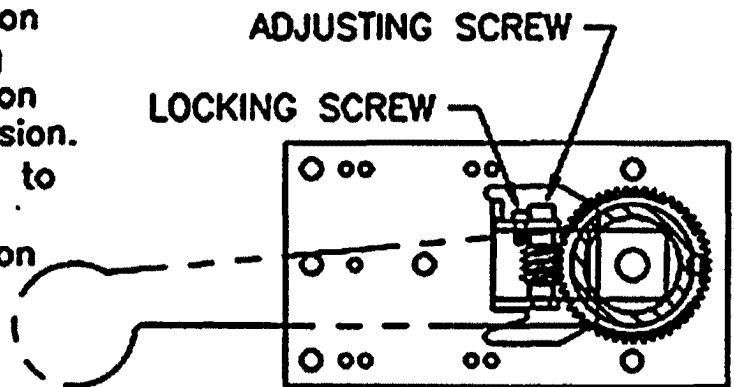

11. Make sure top hinge tube pivot screw and top door pivot shaft set screws are tight. Check all points for interference or lack of clearance at all points.

USE NO LUBRICANTS.

PACIFIC DOOR & CLOSER CO., INC.
 725 Cesar Chavez, San Francisco, CA 94124
 Phone: (800) 995-0573
 Fax: (800) 962-2893
 www.pacificdoorcloser.com

WIKK Balanced Door Parts